

The GLC Coupé



Mercedes-Benz





More than an SUV.
More than a coupé.
More than ever before.

Some personalities immediately make their mark. With their appearance. Their self-assurance. And their unique character. Much like the new GLC Coupé, which combines the merits of an SUV and a coupé like no other. In a style all of its own. More dynamic and sportier than ever.





AMG
MERCEDES-BENZ
C127
C128
C129
C130
C132
C133
C134
C135
C136
C137
C138
C139
C140
C141
C142
C143
C144
C145
C146
C147
C148
C149
C150
C151
C152
C153
C154
C155
C156
C157
C158
C159
C160
C161
C162
C163
C164
C165
C166
C167
C168
C169
C170
C171
C172
C173
C174
C175
C176
C177
C178
C179
C180
C181
C182
C183
C184
C185
C186
C187
C188
C189
C190
C191
C192
C193
C194
C195
C196
C197
C198
C199
C200
C201
C202
C203
C204
C205
C206
C207
C208
C209
C210
C211
C212
C213
C214
C215
C216
C217
C218
C219
C220
C221
C222
C223
C224
C225
C226
C227
C228
C229
C230
C231
C232
C233
C234
C235
C236
C237
C238
C239
C240
C241
C242
C243
C244
C245
C246
C247
C248
C249
C250
C251
C252
C253
C254
C255
C256
C257
C258
C259
C260
C261
C262
C263
C264
C265
C266
C267
C268
C269
C270
C271
C272
C273
C274
C275
C276
C277
C278
C279
C280
C281
C282
C283
C284
C285
C286
C287
C288
C289
C290
C291
C292
C293
C294
C295
C296
C297
C298
C299
C300
C301
C302
C303
C304
C305
C306
C307
C308
C309
C310
C311
C312
C313
C314
C315
C316
C317
C318
C319
C320
C321
C322
C323
C324
C325
C326
C327
C328
C329
C330
C331
C332
C333
C334
C335
C336
C337
C338
C339
C340
C341
C342
C343
C344
C345
C346
C347
C348
C349
C350
C351
C352
C353
C354
C355
C356
C357
C358
C359
C360
C361
C362
C363
C364
C365
C366
C367
C368
C369
C370
C371
C372
C373
C374
C375
C376
C377
C378
C379
C380
C381
C382
C383
C384
C385
C386
C387
C388
C389
C390
C391
C392
C393
C394
C395
C396
C397
C398
C399
C400
C401
C402
C403
C404
C405
C406
C407
C408
C409
C410
C411
C412
C413
C414
C415
C416
C417
C418
C419
C420
C421
C422
C423
C424
C425
C426
C427
C428
C429
C430
C431
C432
C433
C434
C435
C436
C437
C438
C439
C440
C441
C442
C443
C444
C445
C446
C447
C448
C449
C450
C451
C452
C453
C454
C455
C456
C457
C458
C459
C460
C461
C462
C463
C464
C465
C466
C467
C468
C469
C470
C471
C472
C473
C474
C475
C476
C477
C478
C479
C480
C481
C482
C483
C484
C485
C486
C487
C488
C489
C490
C491
C492
C493
C494
C495
C496
C497
C498
C499
C500
C501
C502
C503
C504
C505
C506
C507
C508
C509
C510
C511
C512
C513
C514
C515
C516
C517
C518
C519
C520
C521
C522
C523
C524
C525
C526
C527
C528
C529
C530
C531
C532
C533
C534
C535
C536
C537
C538
C539
C540
C541
C542
C543
C544
C545
C546
C547
C548
C549
C550
C551
C552
C553
C554
C555
C556
C557
C558
C559
C560
C561
C562
C563
C564
C565
C566
C567
C568
C569
C570
C571
C572
C573
C574
C575
C576
C577
C578
C579
C580
C581
C582
C583
C584
C585
C586
C587
C588
C589
C590
C591
C592
C593
C594
C595
C596
C597
C598
C599
C600
C601
C602
C603
C604
C605
C606
C607
C608
C609
C610
C611
C612
C613
C614
C615
C616
C617
C618
C619
C620
C621
C622
C623
C624
C625
C626
C627
C628
C629
C630
C631
C632
C633
C634
C635
C636
C637
C638
C639
C640
C641
C642
C643
C644
C645
C646
C647
C648
C649
C650
C651
C652
C653
C654
C655
C656
C657
C658
C659
C660
C661
C662
C663
C664
C665
C666
C667
C668
C669
C670
C671
C672
C673
C674
C675
C676
C677
C678
C679
C680
C681
C682
C683
C684
C685
C686
C687
C688
C689
C690
C691
C692
C693
C694
C695
C696
C697
C698
C699
C700
C701
C702
C703
C704
C705
C706
C707
C708
C709
C710
C711
C712
C713
C714
C715
C716
C717
C718
C719
C720
C721
C722
C723
C724
C725
C726
C727
C728
C729
C730
C731
C732
C733
C734
C735
C736
C737
C738
C739
C740
C741
C742
C743
C744
C745
C746
C747
C748
C749
C750
C751
C752
C753
C754
C755
C756
C757
C758
C759
C760
C761
C762
C763
C764
C765
C766
C767
C768
C769
C770
C771
C772
C773
C774
C775
C776
C777
C778
C779
C780
C781
C782
C783
C784
C785
C786
C787
C788
C789
C790
C791
C792
C793
C794
C795
C796
C797
C798
C799
C800
C801
C802
C803
C804
C805
C806
C807
C808
C809
C810
C811
C812
C813
C814
C815
C816
C817
C818
C819
C820
C821
C822
C823
C824
C825
C826
C827
C828
C829
C830
C831
C832
C833
C834
C835
C836
C837
C838
C839
C840
C841
C842
C843
C844
C845
C846
C847
C848
C849
C850
C851
C852
C853
C854
C855
C856
C857
C858
C859
C860
C861
C862
C863
C864
C865
C866
C867
C868
C869
C870
C871
C872
C873
C874
C875
C876
C877
C878
C879
C880
C881
C882
C883
C884
C885
C886
C887
C888
C889
C890
C891
C892
C893
C894
C895
C896
C897
C898
C899
C900
C901
C902
C903
C904
C905
C906
C907
C908
C909
C910
C911
C912
C913
C914
C915
C916
C917
C918
C919
C920
C921
C922
C923
C924
C925
C926
C927
C928
C929
C930
C931
C932
C933
C934
C935
C936
C937
C938
C939
C940
C941
C942
C943
C944
C945
C946
C947
C948
C949
C950
C951
C952
C953
C954
C955
C956
C957
C958
C959
C960
C961
C962
C963
C964
C965
C966
C967
C968
C969
C970
C971
C972
C973
C974
C975
C976
C977
C978
C979
C980
C981
C982
C983
C984
C985
C986
C987
C988
C989
C990
C991
C992
C993
C994
C995
C996
C997
C998
C999
C1000

Home | Josh | Search | 12:30

Apps | Comfort | Media Bluetooth

27.0°C | SUGGESTIONS | 27.0°C

25.0°C | 12:30

0 km/h | 15.6 L/100km | 654 km

100 140 180 220 260 km/h | 0 1 2 3 4 5 6 7 8 9 10 x1000rpm

568 km | 102

Mercedes-Benz logo

RES SET + | LIM | VOL | SET -

CVL

AUTO | 1 2 3 4 5 6 7 8 9 10

Q6

27.0°C | SUGGESTIONS | 27.0°C

TEL | NAV | MAP | MORE

The image shows the interior of a Mercedes-Benz GLC Coupé, focusing on the driver's side door panel and dashboard. The door panel features a circular speaker, a silver door handle, and a control panel with buttons for window and mirror adjustments. The dashboard and center console are visible in the foreground, showing a large touch-screen display and various control buttons. The interior is finished with dark leather and brown leather accents. The text "Because communication is everything today." is overlaid on the left side of the image.

Because communication
is everything today.

As well as understanding what you say, the new GLC Coupé also responds instantly to your touches and gestures. This is thanks to MBUX, the sophisticated Mercedes-Benz User Experience, which boasts a wealth of new control and display features. Like the large media display with touch function or the fully digital instrument cluster with navigation display.





Something special. On every trip, from any angle.

The new GLC Coupé is eye-catchingly sporty like never before. With wider aprons, new tailpipe trims and, fitted as standard for the first time, LED High Performance headlamps with sophisticated light design. The optional AMG Line and a host of new wheel designs take its unique sporty and elegant character to the highest level.

The rear end: the start of something new.

The new GLC Coupé's rear end is eye-catchingly athletic and sporty. Powerful contours combine here with sensual, pure lines to dynamic effect. The impressive apron, the stylish chrome elements and the tailpipe trims integrated in the bumper all catch the eye here. The slender LED tail lights featuring a cutting-edge light design are particularly striking.







Sit in an SUV.
Drive a sports coupé.

Every metre and every second become a sporting event in the new GLC Coupé. You can make the new GLC Coupé even more agile with the optional DYNAMIC BODY CONTROL suspension, which lets you individualise the vehicle's damping and handling characteristics. At touch of a button, for a noticeably more comfortable or more dynamic driving experience. Three options are available for this: "Comfort", "Sport" and "Sport+".





Energising comfort and exemplary safety.

During rush hour, on long drives at night or on unfamiliar routes – your new GLC Coupé noticeably takes the strain out of driving, particularly in stressful situations. It's all down to a concept that makes every journey in a Mercedes-Benz a safer and exceptional experience: Mercedes-Benz Intelligent Drive. Because the time you spend behind the wheel is your time. Time for relaxation. Time to replenish your energy. So that, first and foremost, you reach your destination safely, but are also relaxed when you get there.



Driving Assistance package. Hit the road to autonomous driving: cutting-edge systems support you based on the situation with speed adjustment, steering, lane changes and even when there is a risk of collision. The risk of an accident is reduced – passengers and road users are protected effectively. This way you are able to reach your destination relaxed and safe.

The innovative **PRE-SAFE® Sound** system generates a sound signal through the loudspeakers that can trigger a protective reflex: your auditory system briefly disconnects, thereby protecting itself from the loud noise of a crash.

Parking package with 360° camera. Optimum parking service on board. Active Parking Assist with 360° camera makes it easier for you to find a parking space and to manoeuvre into and out of parking spaces. Here the choice is yours: park with ease yourself thanks to all-round visibility – or make things even easier still by getting the car to park for you.



Mercedes-Benz User Experience.

In the new GLC Coupé, you can now control almost everything as intuitively as you do on your smartphone. Simply by using the large touchscreen, the new touchpad, or the Touch Control buttons on the new steering wheel. One touch is all it takes to adjust the display style, the ambient lighting, or the infotainment to meet your needs.



To enable you to find your way in complex traffic situations, **MBUX Augmented Reality Navigation** links the virtual and the real world. The technology incorporates graphical navigation instructions and traffic information into live images. You can get to your destination quickly, safely and stress-free.

EQUIPMENT HIGHLIGHTS: CONTROL AND DISPLAY CONVENIENCE
With **MBUX**, the car's voice control system, it hangs on your every word and talks to you. You can converse with your car in a perfectly natural manner to adjust and control virtually all the functions in the car. Simply say "Hey Mercedes", and the new GLC Coupé will be all ears.



Fully digital instrument cluster.

The fully digital instrument display with the display styles “Classic”, “Progressive” and “Sporty” lets you decide which information is important to you and in which way you wish to have it displayed. The 31.2 cm (12.3-inch) display delivers a pin-sharp image which is easy to read in all light conditions.

Burmester® surround sound system.

With the optional Burmester® surround sound system your new GLC Coupé becomes a concert hall. 13 high-performance speakers, a 9-channel DSP amplifier, a total system output of 590 W, and electronic and acoustic elements tailored precisely to the interior conjure up a unique sound. The surround function and the sound optimisation for the front and rear seats provide an even more intensive listening experience.



MULTIBEAM LED headlamps.

Perfect visibility for you: the adaptive MULTIBEAM LED headlamps with individually controllable LEDs react to the traffic situation. Partial main beam omits other road users without dazzling them. ULTRA RANGE Highbeam increases the range to the permitted maximum. The Active Light System and cornering lights also optimally light up the field of vision.



Sporty wheel design.

There's no stopping the new GLC Coupé – it is forever evolving. An even broader range of exclusive wheels is now available, offering a host of new rim designs. From 45.7 cm (18 inches) to 50.8 cm (20 inches), from elegant to sporty: the choice is yours.

Standard equipment and appointments.

The standard exterior already exudes style all round. This includes exclusive design features in chrome and attractive light-alloy wheels. The visible, chrome-plated tailpipe trim elements underline the vehicle's dynamic look.



The EXCLUSIVE interior.

The EXCLUSIVE interior allows you to show what matters to you: the utmost in elegance and top-class quality down to the most minute detail. The luxurious highlights and fine ambience of your interior, including exclusively styled seats and a dashboard with a high-quality trim, are designed to give you pleasure every day.



The AMG Line.

The expressive bodystyling of the AMG Line lends the exterior a sporty, exclusive touch. Your clear statement for powerful design. The technical features additionally provide you with more tangible driving pleasure, as the sports suspension tuned for agility and coupled with the Sports Direct-Steer system ensures emphatically dynamic handling.



The Night package.

The Night package adds attractive touches: many of the exterior features are finished in black. They underscore the sporty character and special individuality of your vehicle. And they demonstrate your sense of expressive design and exclusive sportiness.





DYNAMIC BODY CONTROL.

With the optional DYNAMIC BODY CONTROL suspension you can adapt the new GLC Coupé's damping and handling characteristics to your individual needs. At the touch of a button, for a noticeably more comfortable or more dynamic driving experience. Three modes are available for this: "Comfort", "Sport" and "Sport+", depending on whether you are looking for particularly comfortable, sporty or extra sporty handling. The damping is continuously variable and is adjusted individually for each wheel. For further enhanced driving safety and ride comfort.

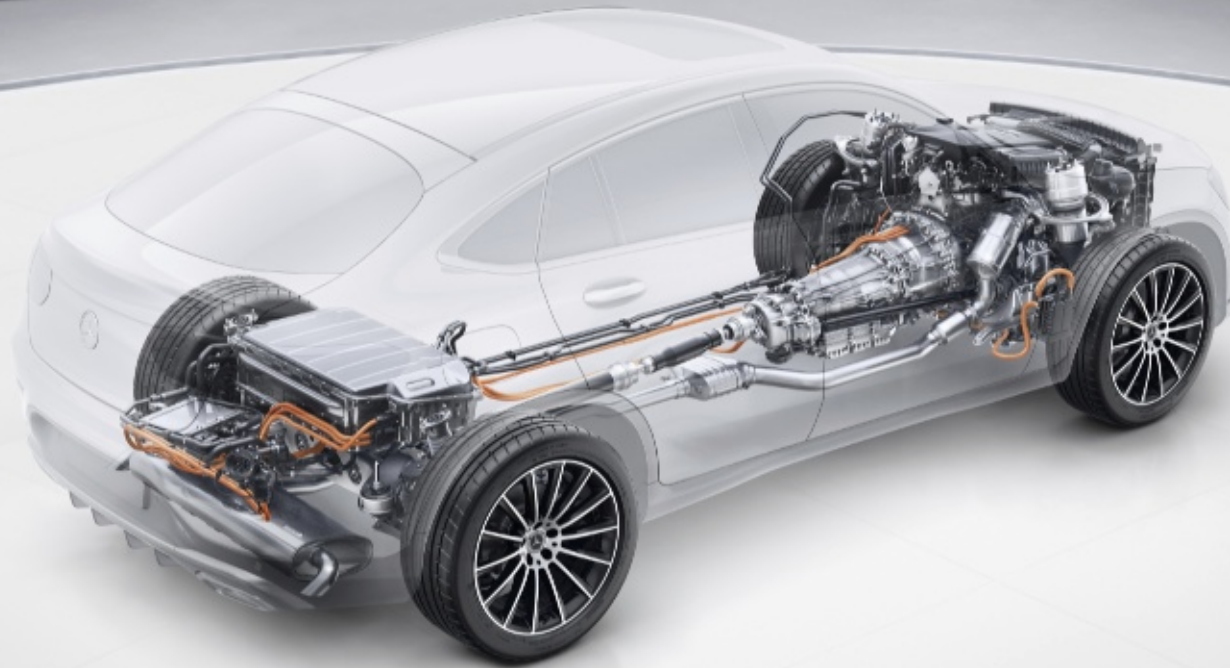

4MATIC all-wheel drive.

On tarmac or light off-road terrain: with 4MATIC, the new GLC Coupé shows its special strengths in adverse weather conditions such as rain, black ice or snow. Thanks to the interplay between the individual wheels, the permanent all-wheel drive is able to ensure exemplary driving stability and traction at all times. For greater dynamism, comfort and safety all round.

Not an SUV. An AMG.

Every Mercedes-AMG is a masterpiece in its own right, with an unmistakable character. What unites our performance vehicles and sports cars is their irrepressible sporting spirit. Their passion for top performance. It is generated at the point where engineering skill meets a very special attitude: the spirit of AMG. We believe that you have to keep on challenging limits in order to achieve new goals. We accept nothing as a given. Because limits are imposed by people, and it's also people who can overcome them. It's this attitude that enables us to achieve outstanding performance for the race track – and for the road.

Welcome to the world of AMG.

www.mercedes-amg.com



AMG
DRIVING PERFORMANCE



Technical data.

Displacement (cc)
Rated output ¹ (kW [hp] at rpm)
Acceleration from 0 to 100 km/h (s)
Top speed (km/h)
Fuel consumption ⁴ (l/100 km)
Urban
Extra-urban
Combined
Combined CO ₂ emissions ⁴ (g/km)
Emissions class ⁵ /efficiency class ⁶

Petrol engines

GLC 300	Mercedes-AMG GLC 43 4MATIC	Mercedes-AMG GLC 63 4MATIC	Mercedes-AMG GLC 63 S 4MATIC
1991	2996	3982	3982
190 (258) 5800-6100	287 (390) 6100	350 (476) 5500-6250	375 (510) 5500-6250
6.3	4.9	4.0	3.8
240	250	250	280
9.6-8.9	14.1-13.6	17.3-16.7	17.0-16.8
7.3-6.0	8.6-8.1	9.8-9.4	9.8-9.5
8.1-7.1	10.5-10.2	12.4-12.2	12.4-12.3
186-162	240-232	283-278	282-280
Euro 4/ B	Euro 4/ F	Euro 4/ G	Euro 4/ G

The best for the engine:
Mercedes-Benz genuine engine oils.

¹ Information about the rated output according to Regulation (EC) No. 715/2007 in the currently valid version. ² Available temporarily. ³ Electronically governed. ⁴ The stated figures were determined according to the prescribed measurement method. They constitute the "NEDC CO₂ figures" pursuant to Article 2 No. 1 Implementing Regulation (EU) 2017/1153. Fuel consumption figures have been calculated on this basis. More information about the official fuel consumption and the official specific CO₂ emissions of new passenger cars is available in the publication entitled "Leitfaden über den Kraftstoffverbrauch, die CO₂-Emissionen und den Stromverbrauch neuer Personenkraftwagen" ["Guidelines concerning the fuel consumption, CO₂ emissions and electricity consumption of new passenger cars"], available free of charge at all retailers and from Deutsche Automobil Treuhand GmbH (www.dat.de). The figures are not based on an individual vehicle and do not constitute part of the product offer; they are provided solely for purposes of comparison between different vehicle models. The figures will vary according to the optional equipment selected. ⁵ Information only valid within the European Union. May vary from country to country. ⁶ Determined on the basis of the measured CO₂ emissions, taking into consideration the vehicle mass. Only valid for Germany. *Weighted electrical consumption (kWh/100 km)/Electric range (km): XXXXXXXX.
Further technical data may be found at

Dimensions.

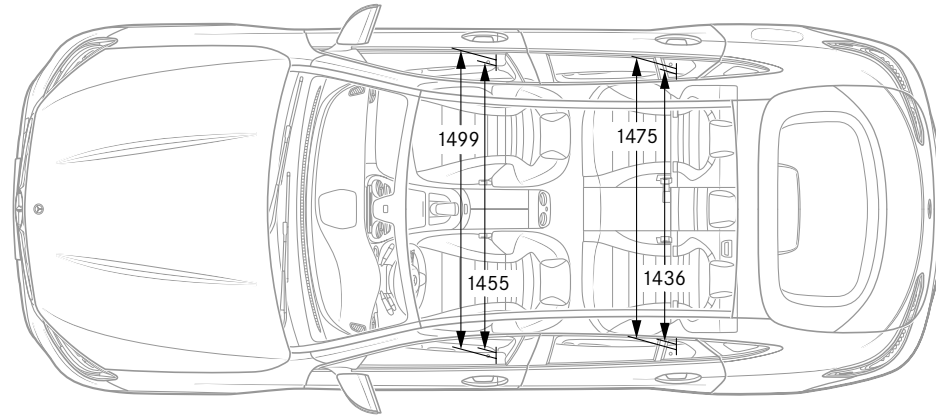
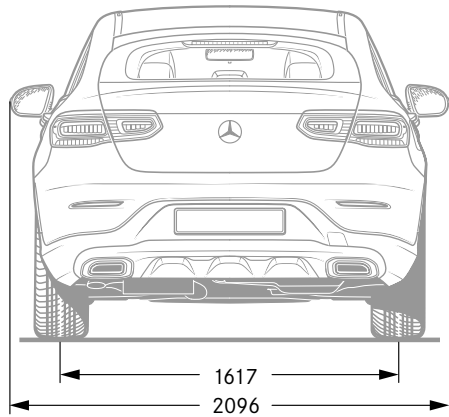
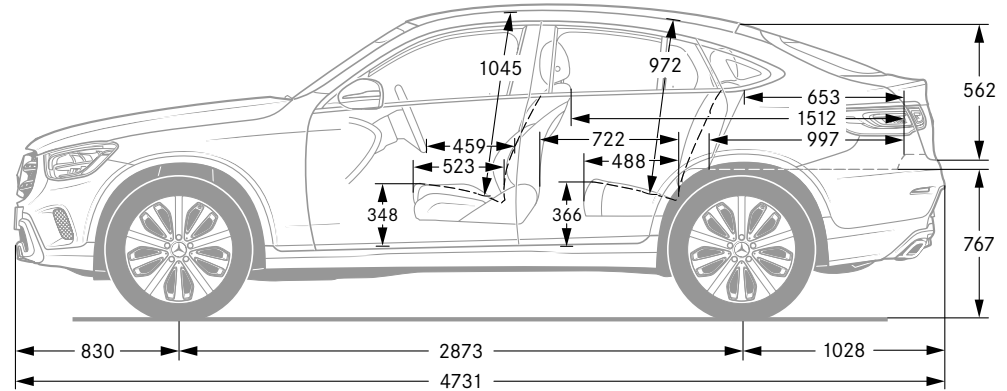
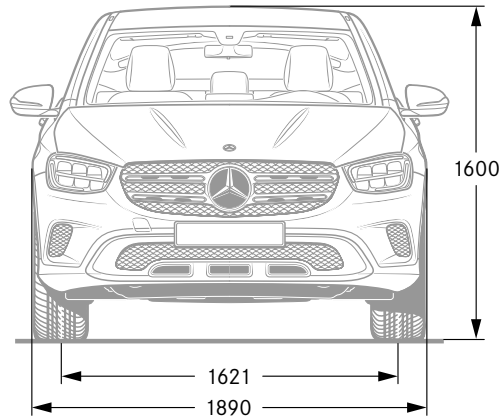

All figures in millimetres. The illustrated dimensions are mean values. They are valid for vehicles in basic specification and in unladen condition.



SPORT - F O R - GOOD

Mercedes-Benz AG is one of the founding partners of the worldwide "Laureus Sport for Good Foundation", which was established in 2000. It is the Mercedes-Benz brand's most important social initiative. Laureus Sport for Good supports children and young people in need through social sports projects, opening up new perspectives and imparting important values such as team spirit, respect and determination. "Change the Game for Kids" is our mission statement which we wish to share with you.

Please note: Changes may have been made to the product since the editorial deadline on 01.10.2019. The manufacturer reserves the right to make changes to the design, form, colour and the product specification during the delivery period, provided these changes, while taking into account the interests of the seller, can be deemed reasonable with respect to the buyer. Where the seller or the manufacturer uses symbols or numbers to describe an order or the

subject of an order, no rights may be derived solely from these. The illustrations may show accessories and items of optional equipment which are not part of standard specification. For the definitive latest information, please contact your nearest authorised Mercedes-Benz AG dealer.